



PART-I: PHYSICS

SECTION - 1: (Only One Option Correct Type)

This section contains **10 multiple choice questions**. Each question has 4 choices (A), (B), (C) and (D) out of which **ONLY ONE is correct**.

1. In the determination of Young's modulus $\left(Y = \frac{4MLg}{\pi d^2} \right)$ by using Searle's method, a wire of

length $L = 2\text{m}$ and diameter $d = 0.5\text{ mm}$ is used. For a load $M = 2.5\text{ kg}$, an extension $= 0.25\text{ mm}$ in the length of the wire is observed. Quantities d and l are measured using a screw gauge and a micrometer, respectively. They have the same pitch of 0.5 mm . The number of divisions on their circular scale is 100 . The contributions to the maximum probable error of the Y measurement

- (A) due to the errors in the measurements of d and l are the same.
 (B) due to the error in the measurement of d is twice that due to the error in the measurement of l .
 (C) due to the error in the measurement of l is twice that due to the error in the measurement of d .
 (D) due to the error in the measurement of d is four times that due to the error in the measurement of l .
2. A small mass m is attached to a mass less string whose other end is fixed at P as shown in the figure. The mass is undergoing circular motion in the x - y plane with centre at O and constant angular speed ω . If the angular momentum of the system, calculated about O and P are denoted by L_o and L_p respectively, then

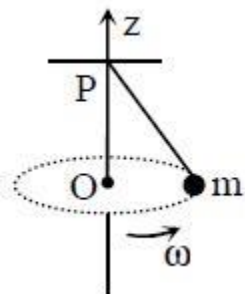

- (A) \vec{L}_o and \vec{L}_p do not vary with time.
 (B) \dot{L}_o varies with time while L_p remains constant.
 (C) \dot{L}_o remains constant while L_p varies with time.
 (D) L_o and L_p both vary with time.



3. A bi-convex lens is formed with two thin plano-convex lenses as shown in the figure. Refractive index n of the first lens is 1.5 and that of the second lens is 1.2. Both the curved surfaces are of the same radius of curvature $R = 14$ cm. For this bi-convex lens, for an object distance of 40 cm, the image distance will be

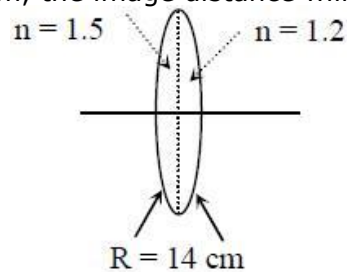

4. A thin uniform rod, pivoted at O , is rotating in the horizontal plane with constant angular speed ω , as shown in the figure. At time $t = 0$, a small insect starts from O and moves with constant speed v , with respect to the rod towards the other end. It reaches the end of the rod at $t = T$ and stops. The angular speed of the system remains ω throughout.

(τ) on the system about O , as a function of time is best represented by which plot?

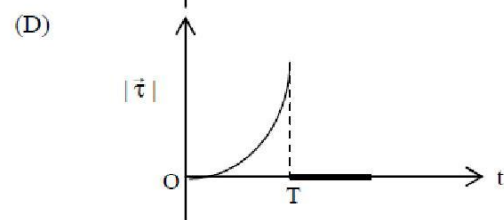
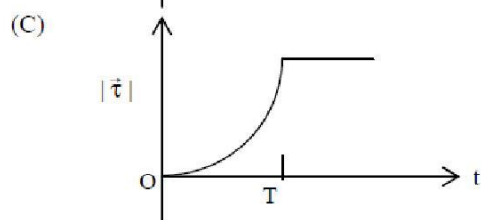
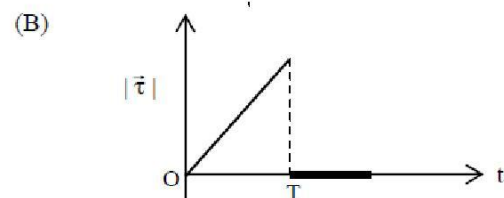
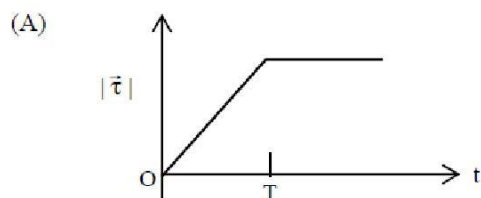
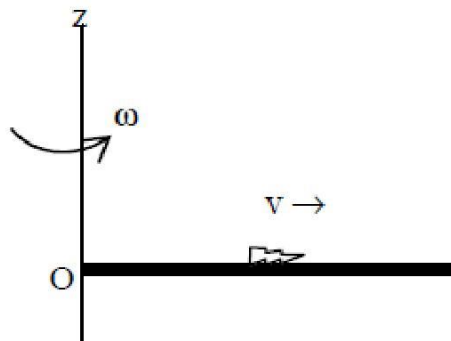



5. A mixture of 2 moles of helium gas (atomic mass = 4 amu) and 1 mole of argon gas (atomic mass = 40 amu) is kept at 300 K in a container. The ratio of the rms speeds

$$\left(\frac{v_{\text{rms}}(\text{helium})}{v_{\text{rms}}(\text{argon})} \right)$$

- (A) 0.32 (B) 0.45 (C) 2.24 (D) 3.16

6. Two large vertical and parallel metal plates having a separation of 1 cm are connected to a DC voltage source of potential difference X. A proton is released at rest midway between the two plates. It is found to move at 45° to the vertical JUST after release. Then X is nearly

- (A) 1×10^{-5} V (B) 1×10^{-7} V (C) 1×10^{-9} V (D) 1×10^{-10} V

7. Three very large plates of same area are kept parallel and close to each other. They are considered as ideal black surfaces and have very high thermal conductivity. The first and third plates are maintained at temperatures 2T and 3T respectively. The temperature of the middle (i.e. second) plate under steady state condition is

- (A) $\left(\frac{65}{2}\right)^{1/4}$ T (B) $\left(\frac{97}{4}\right)^{1/4}$ T (C) $\left(\frac{97}{2}\right)^{1/4}$ T (D) $(97)^{1/4}$ T

8. A small block is connected to one end of a massless spring of un-stretched length 4.9 m. The other end of the spring (see the figure) is fixed. The system lies on a horizontal frictionless surface. The block is stretched by 0.2 m and released from rest at $t = 0$. It

then executes simple harmonic motion with angular frequency $\omega = 3\pi$ rad / s.

Simultaneously at $t = 0$, a small pebble is projected with speed v from point P at an angle of 45° as shown in the figure. Point P is at a horizontal distance of 10 m from O. If the pebble hits the block at $t = 1$ s, the value of v is (take $g = 10 \text{ m/s}^2$)

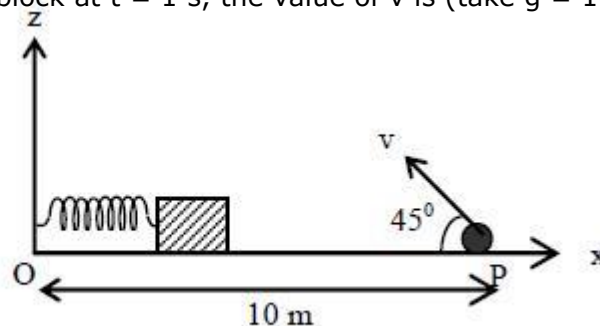

- (A) $\sqrt{50}$ m/s (B) $\sqrt{51}$ m/s (C) $\sqrt{52}$ m/s (D) $\sqrt{53}$ m/s

9. Young's double slit experiment is carried out by using green, red and blue light, one color at a time. The fringe widths recorded are β_G , β_R and β_B respectively. Then,

- (A) $\beta_G > \beta_B > \beta_R$ (B) $\beta_B > \beta_G > \beta_R$ (C) $\beta_R > \beta_B > \beta_G$ (D) $\beta_R > \beta_G > \beta_B$



10. Consider a thin spherical shell of radius R with its centre at the origin, carrying uniform positive surface charge density. The variation of the magnitude of the electric field $E(r)$ and the electric potential $V(r)$ with the distance r from the centre, is best represented by which graph?

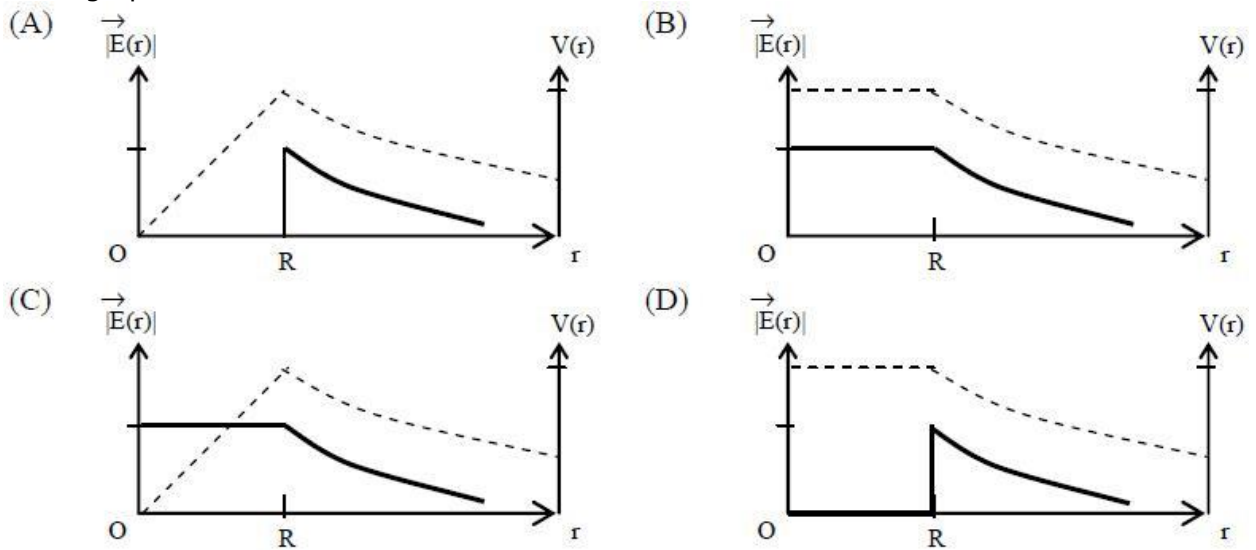

Section II : Multiple Correct Answer(s) Type

This section contains **5 multiple choice questions**. Each question has four choices (A), (B), (C) and (D) out of **which ONE or MORE are correct**.

11. Consider the motion of a positive point charge in a region where there are simultaneous uniform electric and magnetic fields $\vec{E} = E_0 \hat{j}$ and $\vec{B} = B_0 \hat{j}$.
At time $t = 0$, this charge has velocity \vec{v} in the x - y plane, making an angle θ with the x -axis. Which of the following option(s) is (are) correct for time $t > 0$?
- (A) If $\theta = 0^\circ$, the charge moves in a circular path in the x - z plane.
 (B) If $\theta = 0^\circ$, the charge undergoes helical motion with constant pitch along the y -axis.
 (C) If $\theta = 10^\circ$, the charge undergoes helical motion with its pitch increasing with time, along the y -axis.
 the charge undergoes linear but accelerated motion along the y -axis.



12. A cubical region of side a has its centre at the origin. It encloses three fixed point charges, $-q$ at $(0, -a/4, 0)$, $+3q$ at $(0, 0, 0)$ and $-q$ at $(0, +a/4, 0)$. Choose the correct option(s)

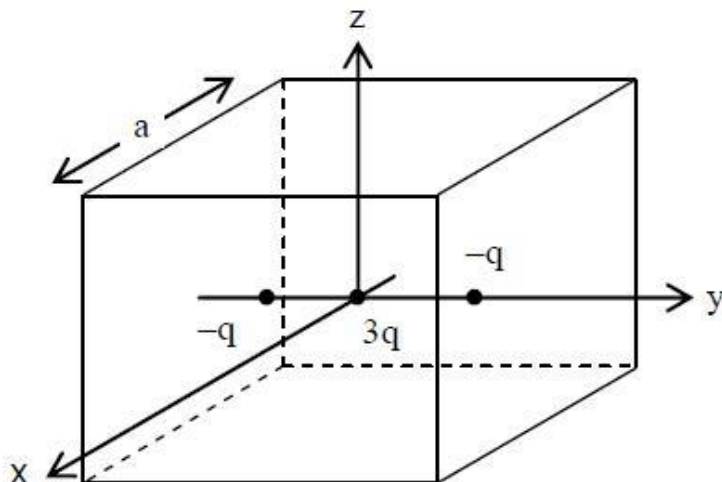

- (A) The net electric flux crossing the plane $x = +a/2$ is equal to the net electric flux crossing the plane $x = -a/2$
- (B) The net electric flux crossing the plane $y = +a/2$ is more than the net electric flux crossing the plane $y = -a/2$.
- (C) The net electric flux crossing the entire region is $\frac{q}{\epsilon_0}$.
- (D) The net electric flux crossing the plane $z = +a/2$ is equal to the net electric flux crossing the plane $x = +a/2$.
13. A person blows into open-end of a long pipe. As a result, a high pressure pulse of air travels down the pipe. When this pulse reaches the other end of the pipe,
- (A) a high-pressure pulse starts travelling up the pipe, if the other end of the pipe is open.
- (B) a low-pressure pulse starts travelling up the pipe, if the other end of the pipe is open.
- (C) a low-pressure pulse starts travelling up the pipe, if the other end of the pipe is closed.
- (D) a high-pressure pulse starts travelling up the pipe, if the other end of the pipe is closed.

14. A small block of mass of 0.1 kg lies on a fixed inclined plane PQ which makes an angle θ with the horizontal. A horizontal force of 1 N acts on the block through its centre of mass as shown in the figure. The block remains stationary if (take $g = 10 \text{ m/s}^2$)

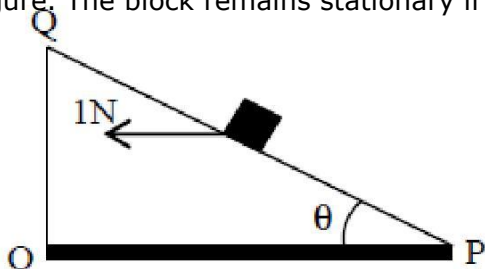

- (A) $\theta = 45^\circ$
- (B) $\theta > 45^\circ$ and a frictional force acts on the block towards P.



- (C) $> 45^\circ$ and a frictional force acts on the block towards Q.
 (D) $< 45^\circ$ and a frictional force acts on the block towards Q.

15. For the resistance network shown in the figure, choose the correct option(s)

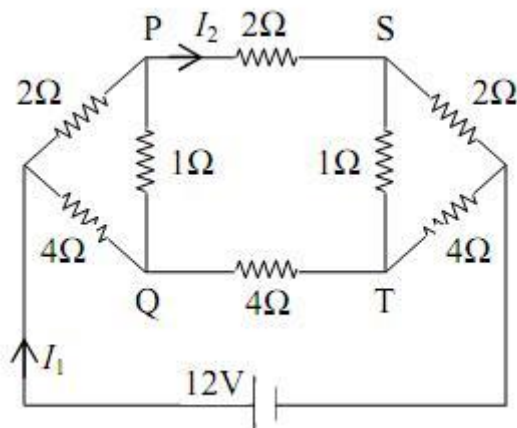

- (A) The current through PQ is zero. (B) $I_1 = 3A$
 (C) The potential at S is less than that at Q. (D) $I_2 = 2A$

Section III : Integer Answer Type

This section contains **5 questions**. The answer to each question is single digit integer, ranging from 0 to 9 (both inclusive).

16. A circular wire loop of radius R is placed in the x - y plane centered at the origin O . A square loop of side a ($a \ll R$) having two turns is placed with its centre at $z = \sqrt{3}R$ along the axis of the circular wire loop, as shown in figure. The plane of the square loop makes an angle of 45° with respect to the z -axis. If the mutual inductance between the

$$\frac{\mu_0 a^2}{2R}$$

loops is given by $2P/2R$ then the value of P is

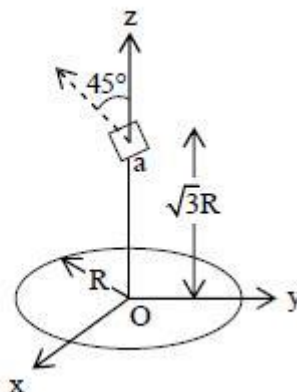



17. An infinitely long solid cylinder of radius R has a uniform volume charge density ρ . It has a spherical cavity of radius $R/2$ with its centre on the axis of the cylinder, as shown in the figure. The magnitude of the electric field at the point P , which is at a distance $2R$ from the axis of the cylinder, is given by the expression $\frac{23\rho R}{k}$. The value of k is $16k\epsilon_0$

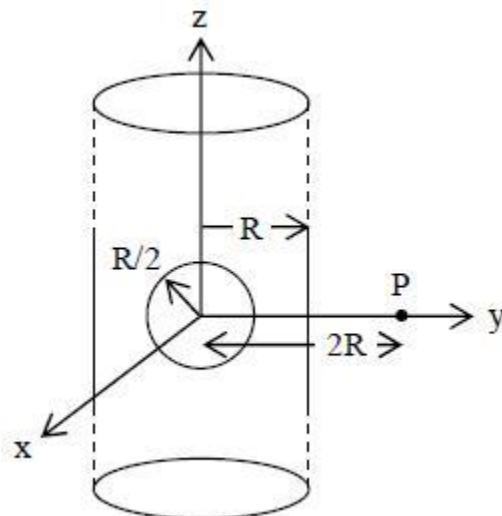

18. A proton is fired from very far away towards a nucleus with charge $Q = 120 e$, where e is the electronic charge. It makes a closest approach of 10 fm to the nucleus. The de Broglie wavelength (in units of fm) of the proton at its start is: (take the proton mass,

$$m_p = (5/3) \times 10^{-27} \text{ kg}; h/e = 4.2 \times 10^{-15} \text{ J.s/C}; \frac{1}{4\pi\epsilon_0} = 9 \times 10^9 \text{ m/F}; 1 \text{ fm} = 10^{-15} \text{ m})$$

19. A lamina is made by removing a small disc of diameter $2R$ from a bigger disc of uniform mass density and radius $2R$, as shown in the figure. The moment of inertia of this lamina about axes passing through O and P is I_O and I_P respectively. Both these axes are perpendicular to the plane of the lamina. The ratio I_P / I_O to the nearest integer is

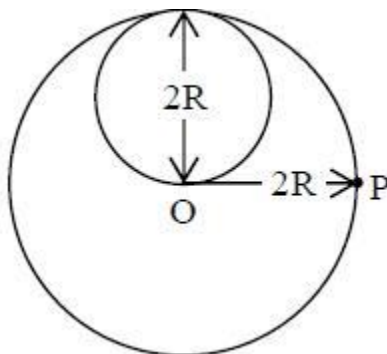



20. A cylindrical cavity of diameter a exists inside a cylinder of diameter $2a$ as shown in the figure. Both the cylinder and the cavity are infinity long. A uniform current density J flows along the length. If the magnitude of the magnetic field at the point P is given by $\frac{N}{12} \mu_0 a J$, then the value of N is

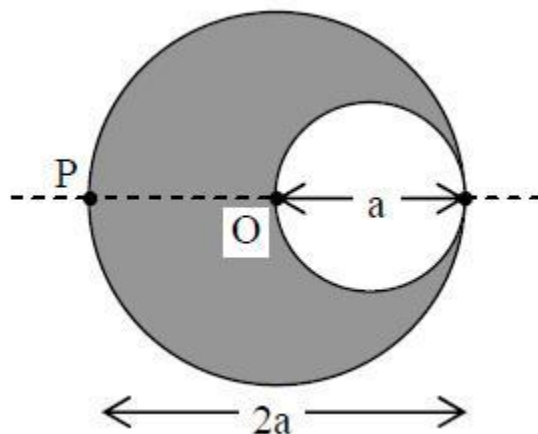

PART-II: CHEMISTRY

SECTION - 1: (Only One Option Correct Type)

This section contains **10 multiple choice questions**. Each question has 4 choices (A), (B), (C) and (D) out of which **ONLY ONE is correct**.

21. A compound $M_p X_q$ has cubic close packing (ccp) arrangement of X . Its unit cell structure is shown below. The empirical formula of the compound is

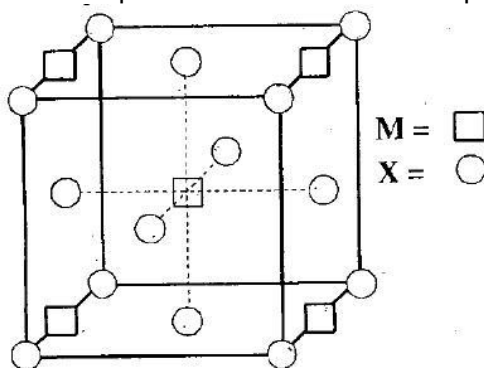

- (A) MX (B) MX_2
(C) M_2X (D) M_5X_{14}

22. The carboxyl functional group ($-\text{COOH}$) is present in

- (A) Picric acid (B) Barbituric acid
(C) Ascorbic acid (D) Aspirin



23. As per IUPAC nomenclature, the name of the complex $[\text{Co}(\text{H}_2\text{O})_4(\text{NH}_3)_2]\text{Cl}_3$ is

- (A) Tetraaquadiammincobalt (III) chloride
- (B) Tetraaquadiammincobalt (III) chloride
- (C) Diaminetetraaquacobalt (III) chloride
- (D) Diamminetetraaquacobalt (III) chloride

24. In allene (C_3H_4), the type(s) of hybridization of the carbon atoms is (are)

- (A) sp and sp^3
- (B) sp and sp^2
- (C) Only sp^2
- (D) sp^2 and sp^3

25. The kinetic energy of an electron in the second Bohr orbit of a hydrogen atom is [a_0 is Bohr radius]

- (A) $\frac{h^2}{4\pi^2 m a_0^2}$
- (B) $\frac{h^2}{16\pi^2 m a_0^2}$
- (C) $\frac{h^2}{32\pi^2 m a_0^2}$
- (d) $\frac{h^2}{64\pi^2 m a_0^2}$

26. Which ordering of compounds is according to the decreasing order of the oxidation state of nitrogen?

- (A) HNO_3 , NO , NH_4Cl , N_2
- (B) HNO_3 , NO , N_2 , NH_4Cl
- (C) HNO_3 , NH_4Cl , NO , N_2
- (D) NO , HNO_3 , NH_4Cl , N_2

27. For one mole of a van der Waals gas when $b = 0$ and $T = 300 \text{ K}$, the PV vs. $1/V$ plot is shown below. The value of the van der Waals constant a ($\text{atm} \cdot \text{litre}^2 \text{ mol}^{-2}$) is

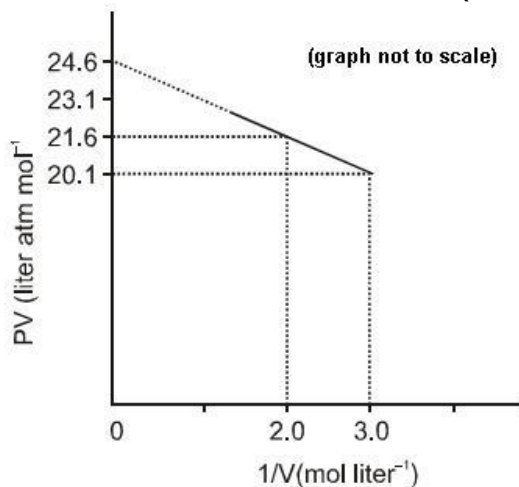

- (A) 1.0
- (B) 4.5
- (C) 1.5
- (D) 3.0



28. The number of aldol reaction(s) that occurs in the given transformation is

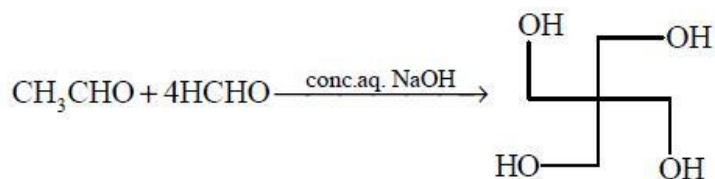

- (A) 1 (B) 2
(C) 3 (D) 4

29. The colour of light absorbed by an aqueous solution of CuSO_4 is

- (A) orange-red (B) blue-green
(C) Yellow (D) violet

30. The number of optically active products obtained from the complete ozonolysis of the given compound is

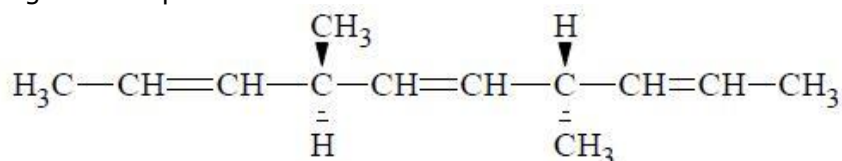

- (A) 0 (B) 1
(C) 2 (D) 4

Section II (One or More Options Correct Type)

This section contains **5 multiple choice questions**. Each question has four choices (A), (B), (C) and (D) out of which **ONE OR MORE** are correct.

31. Which of the following hydrogen halides react(s) with AgNO_3 (aq) to give a precipitate that dissolves in $\text{Na}_2\text{S}_2\text{O}_3$ (aq) ?

- (A) HCl (B) HF
(C) HBr (D) HI

32. Identify the binary mixture(s) that can be separated into individual compounds, by differential extraction, as shown in the given scheme.

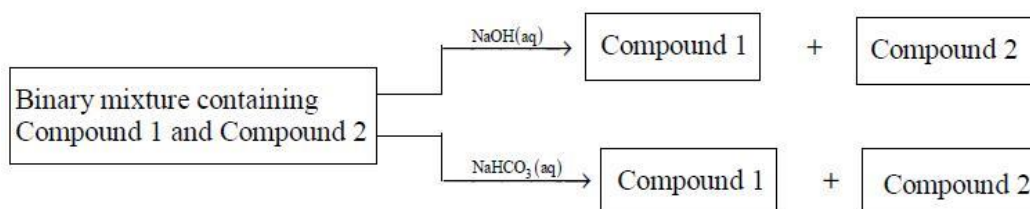

- (A) $\text{C}_6\text{H}_5\text{OH}$ and $\text{C}_6\text{H}_5\text{COOH}$ (B) $\text{C}_6\text{H}_5\text{COOH}$ and $\text{C}_6\text{H}_5\text{CH}_2\text{OH}$
(C) $\text{C}_6\text{H}_5\text{CH}_2\text{OH}$ and $\text{C}_6\text{H}_5\text{OH}$ (D) $\text{C}_6\text{H}_5\text{CH}_2\text{OH}$ and $\text{C}_6\text{H}_5\text{CH}_2\text{COOH}$

33. For an ideal gas, consider only P-V work in going from an initial state X to the final state Z. The final state Z can be reached by either of the two paths shown in the figure. Which



of the following choice(s) is (are) correct? [Take ΔS as change in entropy and w as work done]

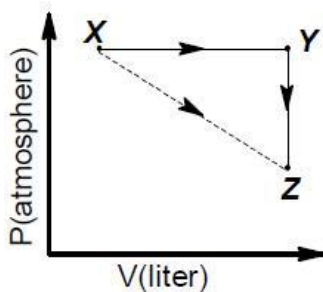

(A) $\Delta S_{X \rightarrow Z} = \Delta S_{X \rightarrow Y} + \Delta S_{Y \rightarrow Z}$

(C) $W_{X \rightarrow Y \rightarrow Z} = W_{X \rightarrow Y}$

(B) $W_{X \rightarrow Z} = W_{X \rightarrow Y} + W_{Y \rightarrow Z}$

(D) $\Delta S_{X \rightarrow Y \rightarrow Z} = \Delta S_{X \rightarrow Y}$

34. Which of the following molecules, in pure form, is (are) unstable at room temperature?

(A)



(B)



(C)

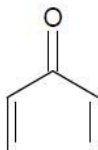

(D)



35. Choose the correct reason(s) for the stability of the lyophobic colloidal particles.

- (A) Preferential adsorption of ions on their surface from the solution
- (B) Preferential adsorption of solvent on their surface from the solution
- (C) Attraction between different particles having opposite charges on their surface
- (D) Potential difference between the fixed layer and the diffused layer of opposite charges around the colloidal particles.

Section III: (Integer Value Correct Type)

This section contains **5 questions**. The answer to each question is a **single digit integer**, ranging from 0 to 9 (both inclusive).

36. 29.2 % (w/w) HCl stock solution has density of 1.25 g mL^{-1} . The molecular weight of HCl is 36.5 g mol^{-1} . The volume (mL) of stock solution required to prepare a 200 mL solution of 0.4 M HCl is



37. The substituents R_1 and R_2 for nine peptides are listed in the table given below. How many of these peptides are positively charged at $\text{pH} = 7.0$?

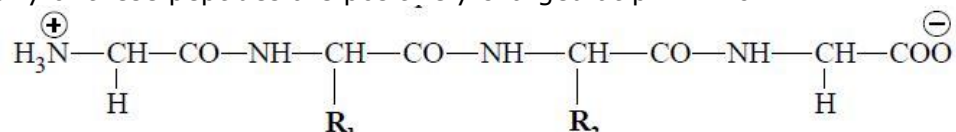

Peptide	R_1	R_2
I	H	H
II	H	CH_3
III	CH_2COOH	H
IV	CH_2CONH_2	$(\text{CH}_2)_4\text{NH}_2$
V	CH_2CONH_2	CH_2CONH_2
VI	$(\text{CH}_2)_4\text{NH}_2$	$(\text{CH}_2)_4\text{NH}_2$
VII	CH_2COOH	CH_2CONH_2
VIII	CH_2OH	$(\text{CH}_2)_4\text{NH}_2$
IX	$(\text{CH}_2)_4\text{NH}_2$	CH_3

38. An organic compound undergoes first-order decomposition. The time taken for its decomposition to $1/8$ and $1/10$ of its initial concentration are $t_{1/8}$ and $t_{1/10}$ respectively.

What is the value of $\frac{[t_{1/8}]}{[t_{1/10}]}$ $\times 10$? (take $\log_{10}2 = 0.3$)

39. When the following aldohexose exists in its D-configuration, the total number of stereoisomers in its pyranose form is



40. The periodic table consists of 18 groups. An isotope of copper, on bombardment with protons, undergoes a nuclear reaction yielding element X as shown below. To which group, element X belongs in the periodic table?

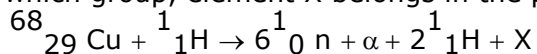



PART-III: MATHEMATICS

SECTION - 1: Single Correct Answer Type

This section contains **10 multiple choice questions**. Each question has 4 choices (A), (B), (C) and (D) out of which **ONLY ONE is correct**.

41. If $\lim_{x \rightarrow \infty} \left(\frac{x^2 + x + 1}{x + 1} - ax - b \right) = 4$, then

- (A) $a = 1, b = 4$ (B) $a = 1, b = -4$
 (C) $a = 2, b = -3$ (D) $a = 2, b = 3$

42. Let $P = [a_{ij}]$ be a 3×3 matrix and let $Q = [b_{ij}]$, where $b_{ij} = 2^{i+j} a_{ij}$ for $1 \leq i, j \leq 3$. If the determinant of P is 2, then the determinant of the matrix Q is

- (A) 2^{10} (B) 2^{11}
 (C) 2^{12} (D) 2^{13}

43. The locus of the mid-point of the chord of contact of tangents drawn from points lying on the straight line $4x - 5y = 20$ to the circle $x^2 + y^2 = 9$ is

- (A) $20(x^2 + y^2) - 36x + 45y = 0$ (B) $20(x^2 + y^2) + 36x - 45y = 0$
 (C) $36(x^2 + y^2) - 20x + 45y = 0$ (D) $36(x^2 + y^2) + 20x - 45y = 0$

44. The total number of ways in which 5 balls of different colours can be distributed among 3 persons so that each person gets at least one ball is

- (A) 75 (B) 150
 (C) 210 (D) 243

45. The integral $\int \frac{\sec^2 x}{(\sec x + \tan x)^{9/2}} dx$ equals (for some arbitrary constant K)

- (A) $-\frac{1}{11/2} \left\{ \frac{1}{11} - \frac{1}{7} (\sec x + \tan x)^2 \right\} + K$
 (B) $\frac{1}{11/2} \left\{ \frac{1}{11} - \frac{1}{7} (\sec x + \tan x)^2 \right\} + K$
 (C) $-\frac{1}{11/2} \left\{ \frac{1}{11} + \frac{1}{7} (\sec x + \tan x)^2 \right\} + K$
 (D) $\frac{1}{11/2} \left\{ \frac{1}{11} + \frac{1}{7} (\sec x + \tan x)^2 \right\} + K$



46. The point P is the intersection of the straight line joining the points Q(2, 3, 5) and R(1, -1, 4) with the plane $5x - 4y - z = 1$. If S is the foot of the perpendicular drawn from the point T (2, 1, 4) to QR, then the length of the line segment PS is

- (A) $\frac{1}{\sqrt{2}}$ (B) $\sqrt{2}$
(C) 2 (D) $2\sqrt{2}$

47. Let $f(x) = \begin{cases} 2 \left| \cos \frac{\pi}{x} \right|, & x \neq 0 \\ 0, & x = 0 \end{cases}$, $x \in \mathbb{R}$, then f is

- (A) Differentiable both at $x = 0$ and at $x = 2$
(B) Differentiable at $x = 0$ but not differentiable at $x = 2$
(C) Not differentiable at $x = 0$ but differentiable at $x = 2$
(D) Differentiable neither at $x = 0$ nor at $x = 2$

48. Let z be a complex number such that the imaginary part of z is non zero and $a = z^2 + z + 1$ is real. Then a cannot take the value

- (A) -1 (B) $\frac{1}{3}$
(C) $\frac{1}{2}$ (D) $\frac{3}{4}$

49. The ellipse $E_1 : \frac{x^2}{9} + \frac{y^2}{4} = 1$ is inscribed in a rectangle R whose sides are parallel to the coordinate axes. Another ellipse E_2 passing through the point (0, 4) circumscribes the rectangle R. The eccentricity of the ellipse E_2 is

- (A) $\frac{\sqrt{2}}{2}$ (B) $\frac{\sqrt{3}}{2}$
(C) $\frac{1}{2}$ (D) $\frac{3}{4}$

50. The function $f: [0, 3] \rightarrow [1, 29]$, defined by $f(x) = 2x^3 - 15x^2 + 36x + 1$, is

- (A) one-one and onto (B) onto but not one-one
(C) one-one but not onto (D) neither one-one nor onto



SECTION - 2: (One or More Options Correct Type)

This section contains **5 multiple choice questions**. Each question has four choices (A), (B), (C) and (D) out of which **ONE OR MORE are correct**.

51. Tangents are drawn to the hyperbola $\frac{x^2}{9} - \frac{y^2}{4} = 1$, parallel to the straight line $2x - y = 1$.

The points of contact of the tangents on the hyperbola are

(A) $\left(\frac{9}{2\sqrt{2}}, \frac{1}{\sqrt{2}} \right)$ (B) $\left(-\frac{9}{2\sqrt{2}}, -\frac{1}{\sqrt{2}} \right)$

(C) $(3\sqrt{3}, -2\sqrt{2})$ (D) $(-3\sqrt{3}, 2\sqrt{2})$

52. Let $\theta, \phi \in [0, 2\pi]$ be such that $2 \cos \theta (1 - \sin \phi) = \sin^2 \theta \left(\tan \frac{\theta}{2} + \cot \frac{\theta}{2} \right) \cos \phi - 1$,

$\tan(2\pi - \theta) > 0$ and $-1 < \sin \theta < -\frac{\sqrt{3}}{2}$. Then ϕ cannot satisfy

(A) $0 < \phi < \frac{\pi}{2}$ (B) $\frac{\pi}{2} < \phi < \frac{4\pi}{3}$

(C) $\frac{4\pi}{3} < \phi < \frac{3\pi}{2}$ (D) $\frac{3\pi}{2} < \phi < 2\pi$

53. If $y(x)$ satisfies the differential equation $y' - y \tan x = 2x \sec x$ and $y(0) = 0$, then

(A) $y \Big|_{\left(\frac{\pi}{4} \right)} = \frac{\pi^2}{8\sqrt{2}}$

(B) $y' \Big|_{\left(\frac{\pi}{4} \right)} = \frac{\pi^2}{18}$

(C) $y \Big|_{\left(\frac{\pi}{3} \right)} = \frac{\pi^2}{9}$

(D) $y' \Big|_{\left(\frac{\pi}{3} \right)} = \frac{4\pi}{3} + \frac{2\pi^2}{3\sqrt{3}}$



54. A ship is fitted with three engines E_1 , E_2 and E_3 . The engines function independently of each other with respective probabilities $\frac{1}{2}$, $\frac{1}{4}$ and $\frac{1}{4}$. For the ship to be operational at least two of its engines must function. Let X denotes the event that the ship is operational and let X_1 , X_2 and X_3 denotes respectively the events that the engines E_1 , E_2 and E_3 are functioning. Which of the following is (are) true?

(A) $P\left[\binom{X_1 X_2 X_3}{1}\right] = \frac{3}{16}$

(B) $P\left[\text{Exactly two engines of the ship are functioning} \mid X\right] = \frac{1}{8}$

(C) $P\left[X \mid X_2\right] = \frac{5}{16}$

(D) $P\left[\binom{X_1 X_2 X_3}{1}\right] = \frac{7}{16}$

55. Let S be the area of the region enclosed by $y = e^{-x^2}$, $y = 0$, $x = 0$ and $x = 1$. then

(A) $S \geq \frac{1}{e}$

(B) $S \geq 1 - \frac{1}{e}$

(C) $S \leq \frac{1}{4} \left(1 + \frac{1}{\sqrt{e}}\right)$

(D) $S \leq \frac{1}{\sqrt{2}} + \frac{1}{\sqrt{e}} \left(1 - \frac{1}{\sqrt{2}}\right)$

SECTION - 3: (Integer Value Correct Type)

This section contains **5 questions**. The answer to each question is a **single digit integer**, ranging from 0 to 9 (*both inclusive*).

56. If \vec{a} , \vec{b} and \vec{c} are unit vectors satisfying $|\vec{a} - \vec{b}|^2 + |\vec{b} - \vec{c}|^2 + |\vec{c} - \vec{a}|^2 = 9$, then $|2\vec{a} + 5\vec{b} + 5\vec{c}|$ is

57. Let $f : \mathbb{R} \rightarrow \mathbb{R}$ be defined as $f(x) = x + x^2 - 1$. The total number of points at which f attains either a local maximum or a local minimum is

58. Let S be the focus of the parabola $y^2 = 8x$ and let PQ be the common chord of the circle $x^2 + y^2 - 2x - 4y = 0$ and the given parabola. The area of the triangle PQS is



59. Let $p(x)$ be a real polynomial of least degree which has a local maximum at $x = 1$ and a local minimum at $x = 3$. If $p(1) = 6$ and $p(3) = 2$, then $p'(0)$ is

60. The value of $6 + \log_{\frac{3}{2}} \left(\frac{1}{\sqrt[3]{2}} \sqrt{4 - \frac{1}{\sqrt[3]{2}}} \sqrt{4 - \frac{1}{\sqrt[3]{2}}} \sqrt{4 - \frac{1}{\sqrt[3]{2}}} \dots \right)$ is